

ARGUS

**Sierra Radio Systems
Station Controller**

Argus Data Logger Reference Manual



Version 1

sierraradio.net

ARGUS

Introduction

The SRS Data Logger module is a WiFi or DCN connected sensor control module that provides switch closure monitoring, DC volt meters, temperature measurement and a dry contact SPST relay.

The development of the Argus Data Logger is in collaboration with RepeaterBook.



Argus can be connected to the RepeaterBook Vista servers. When connecting Argus to a repeater's COR signal or a mobile radio's COS output pin, Argus will count the number of keyups and the duration of the transmission. This data is uploaded over the internet to RepeaterBook.



Repeater Activity Monitoring



View Results on RepeaterBook



Measure Keyups & Transmission Times



Public or Private Data



Measure DC Voltage



Station Controller Compatible



Measure Temperature



WiFi Connected

Connections

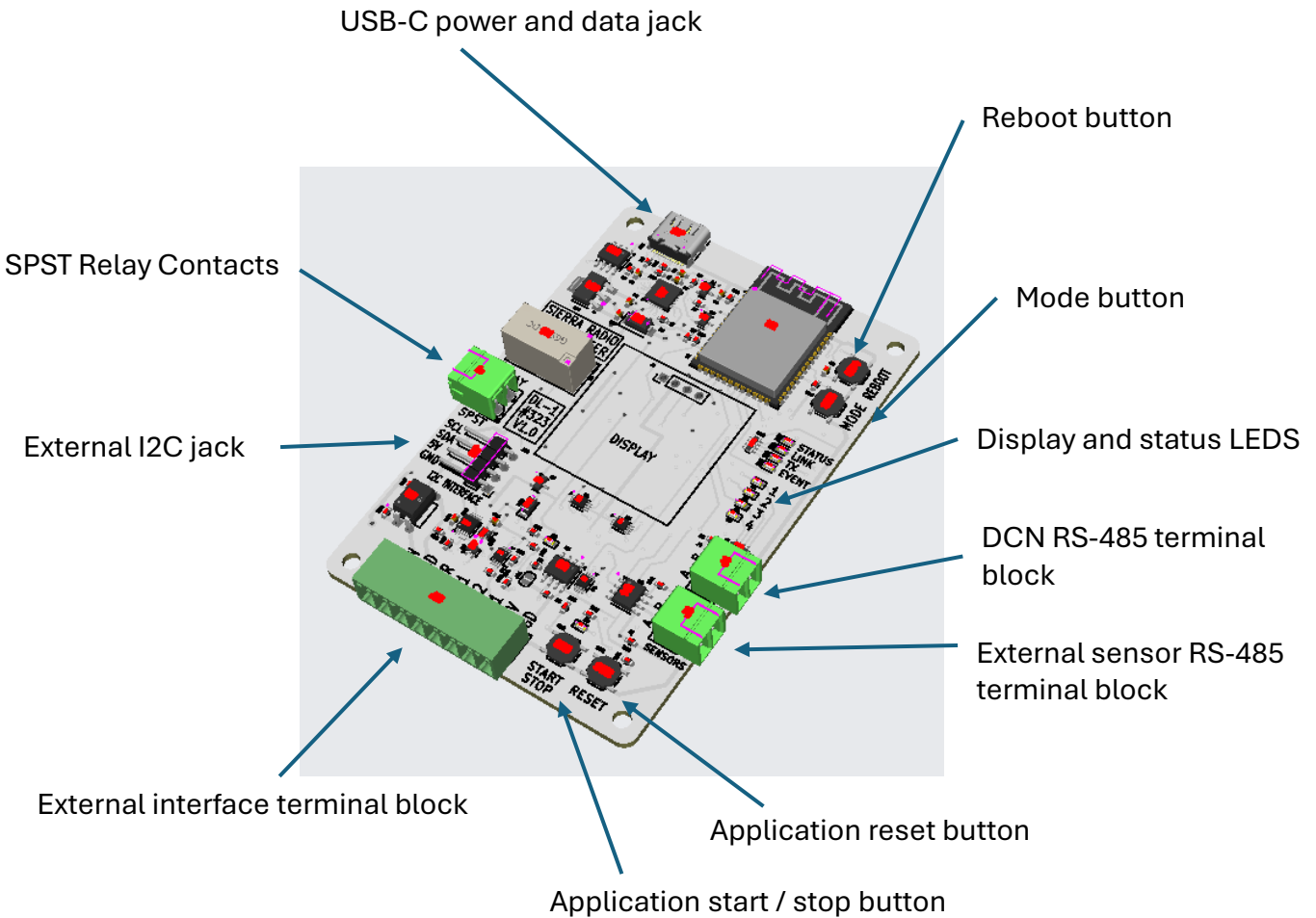

USB-C Power & Data Jack

The data logger is powered by the USB-C jack. This is also the port used to update the firmware on the module.

External Interface Terminal Block

This terminal block provides connections to switch closure (event) input, DC volt meter inputs and the digital temperature sensor input.

External I2C Jack

This header connector is used to interface to external I2C devices including serial LCD displays.

SPST Relay Contacts

This terminal block provides the two dry contacts of the SPST relay.

External Interface Terminal Block Pins

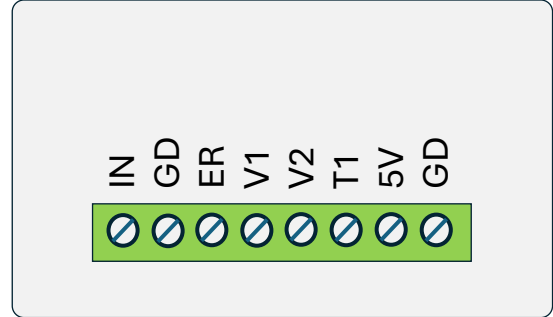

IN - Event logger input.

This is an active pull to ground through an internal opto-isolator. When this pin is grounded, the data logger will register the beginning of an event and send event and time stamp to the server.

When the pin is released from ground, the data logger will register the end of the event and send the the event and times stamp to the server.

GD - Ground

ER - Event Reset.

When this pin is pulled to ground, the event count will reset to zero.
This is the same function as the RESET button.

V1 - DC Volt meter #1 input.

V2 - DC Volt meter #2 input.

The meter measures 0-60 VDC and are referenced to system ground.

T1 - Digital temperature sensor input.

T1 is the yellow wire on the temperature sensor cable.

Connect the cable's red wire to the 5V terminal.

Connect the cable's black wire to the ground terminal

5V - +5V DC out to power the digital temperature sensor.

GD - Ground

For repeater activity monitoring the COS (Carrier Operated Switch) output of a repeater receiver often is a signal that is pulled to ground when active.

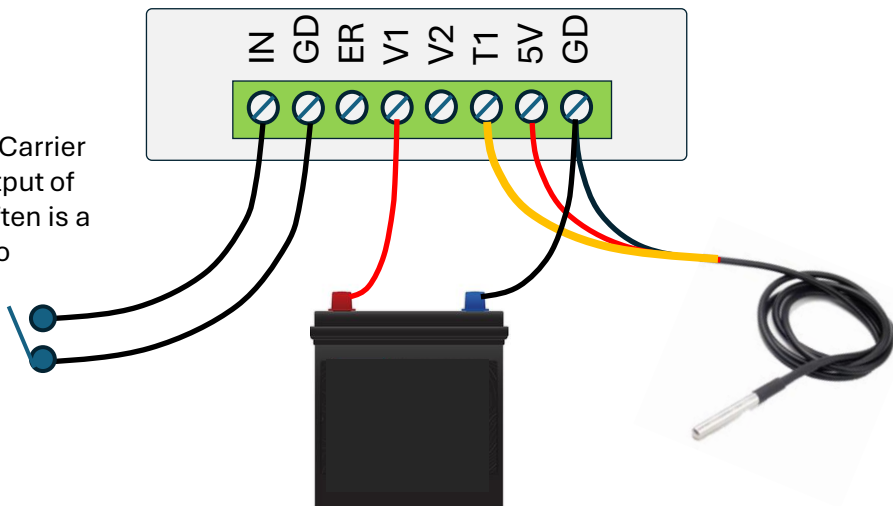

Buttons

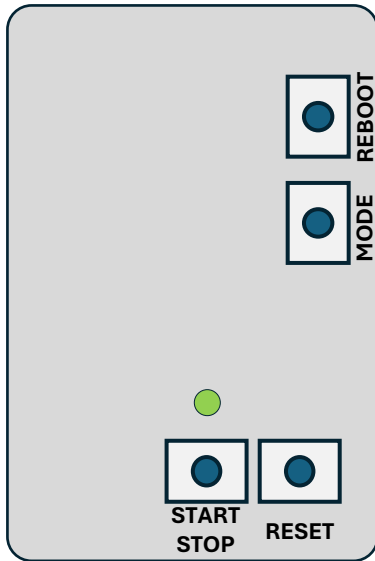

REBOOT

This button reboots the data logger.

MODE

This button is used to set the operating mode of the data logger module.

START / STOP

The start stop button is used to start recording data and stopping the process. When logging data and updating the remote server, the green LED above the button will be on.

RESET

The reset button will set the current event count to zero.

Data Jacks and Relay Contacts

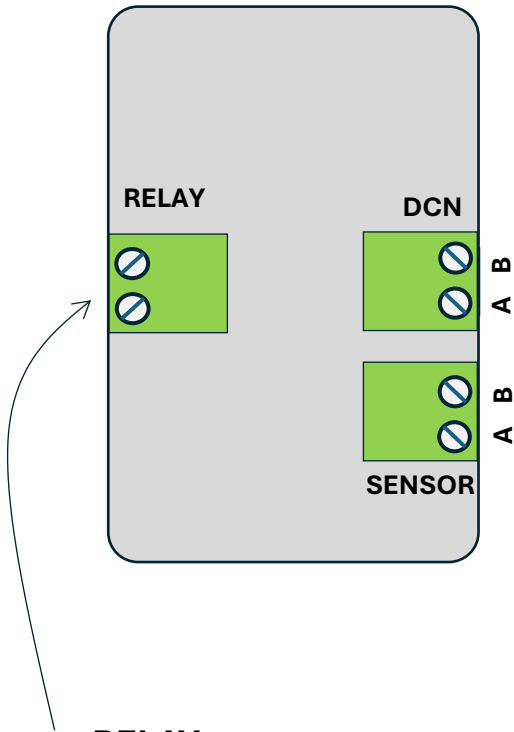

DCN

The two pin terminal block is used to connect this data logger module to an internet gateway like the #310 RPI Host Adapter.

Pin 1 – RS-485A

Pin 2 – RS-485B

SENSOR

The two pin terminal block is used to connect this data logger module to an external RS485 sensor modules.

Pin 1 – RS-485A

Pin 2 – RS-485B

RELAY

The relay terminal block provide a SPST dry contact pair rated for 2 Amps.

Status LEDS

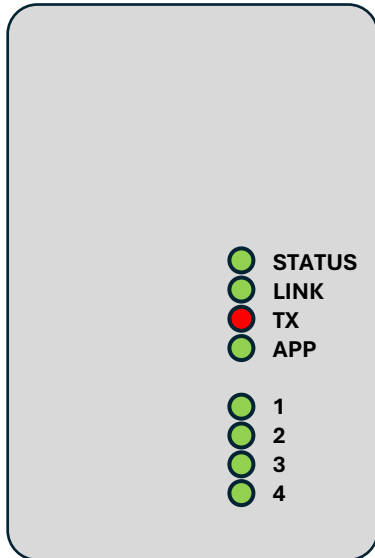

STATUS

This LED indicates the general condition of the module. A solid LED indicates the module is in operation.

LINK

The LINK LED indicates when the module is connected to the data logging server.

TX

This LED indicates when data is being sent from the module to the DCN network.

APP

This LED indicates information about the data logging application .

1 .. 4

These LED's are application specific. Often found scanning from 1 to 4 to indicate the module is in normal use.