

Sierra Radio Systems Station Controller

Basic Installation and Setup Guide



sierraradio.net

Version 1

Hardware Installation Basics

What do you need to install the Station Controller?

- Raspberry Pi host adapter module
- Raspberry Pi. We recommend the RPI 3
- 16 GB micro SD card
- One or more Station Control modules (GPIO, coax relay, watt meter, etc)
- 12-15 volt DC power supply rated for at least 3 amps with powerpole or 2.1mm dc plug
- 2.5mm flat edge screwdriver
- CAT5 or CAT6 cables to connect modules. One per module.
- Mounting surface

Optional

- DIN rails if you plan on mounting your system using DIN rail clips
- Keyboard, mouse and monitor to plug into the Raspberry Pi for customization

The Station Controller is very easy to install and use “out of box”. The basic steps are...

1. Mount the hardware modules.
2. Connect the modules with common CAT5 / CAT6 cables.
3. Install the pre-imaged Raspberry Pi SD card
4. Apply power to the Powerpole or barrel jack on the Raspberry Pi module.
5. Point your web browser to the Node Red Station Controller dashboard

Now you can test the Station Controller. Use the dashboard to flip relays, select antenna ports, read voltages, etc.

For more information go to
sierraradio.net

Typical Hardware Installation

This example shows a typical system mounted to a plywood board using DIN rails and clips.

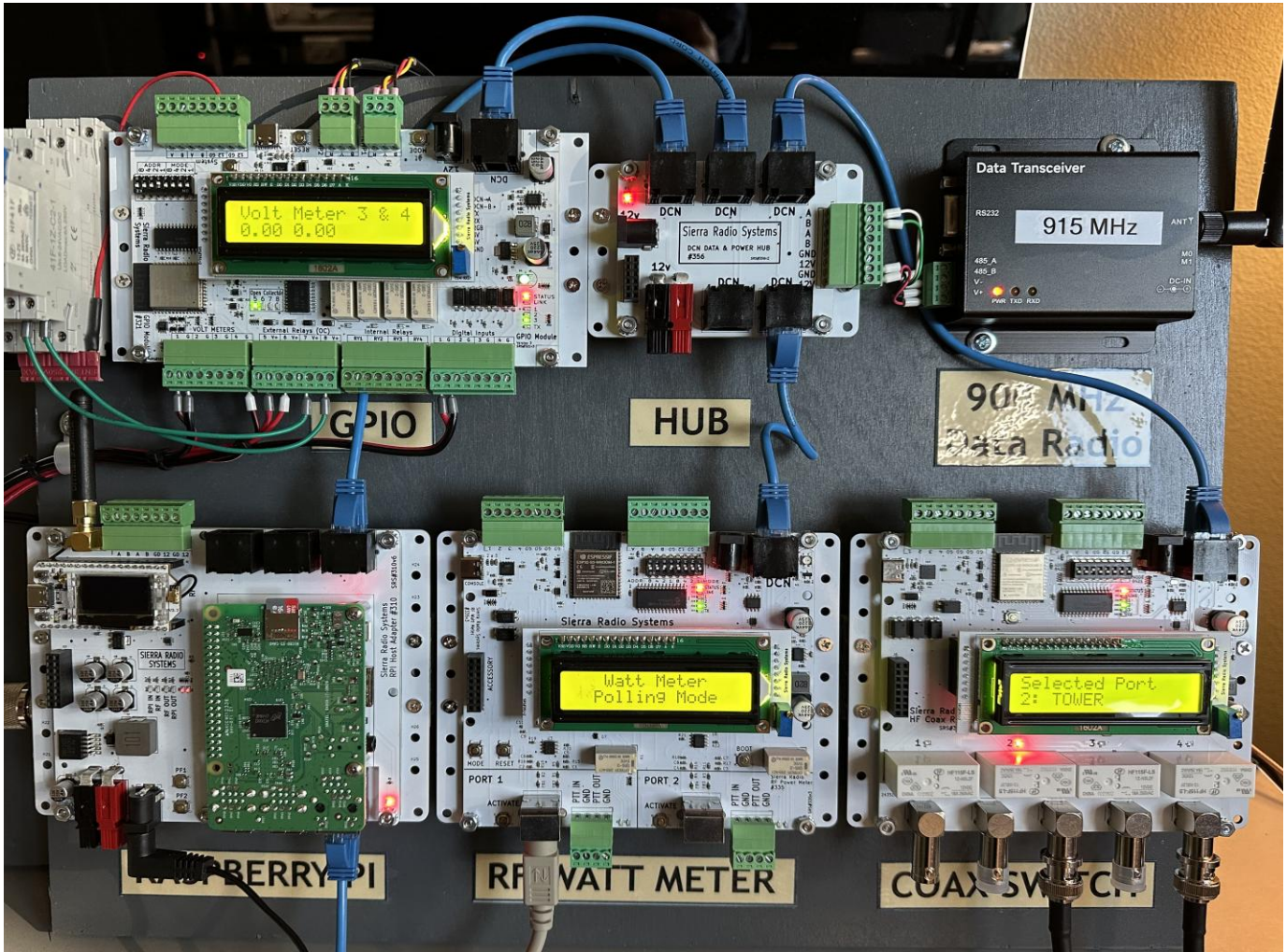

In the example pictured above you can see a full system including from top left:

- 4 external sim 6A DIN rail mounted relays
- GPIO Module
- Coax Relay Module
- After market DIN rail mounted DC power meter monitoring the power to the system

On the bottom row from the left:

- Raspberry Pi Module
- Data / Power Hub Module
- RF Watt Meter Module

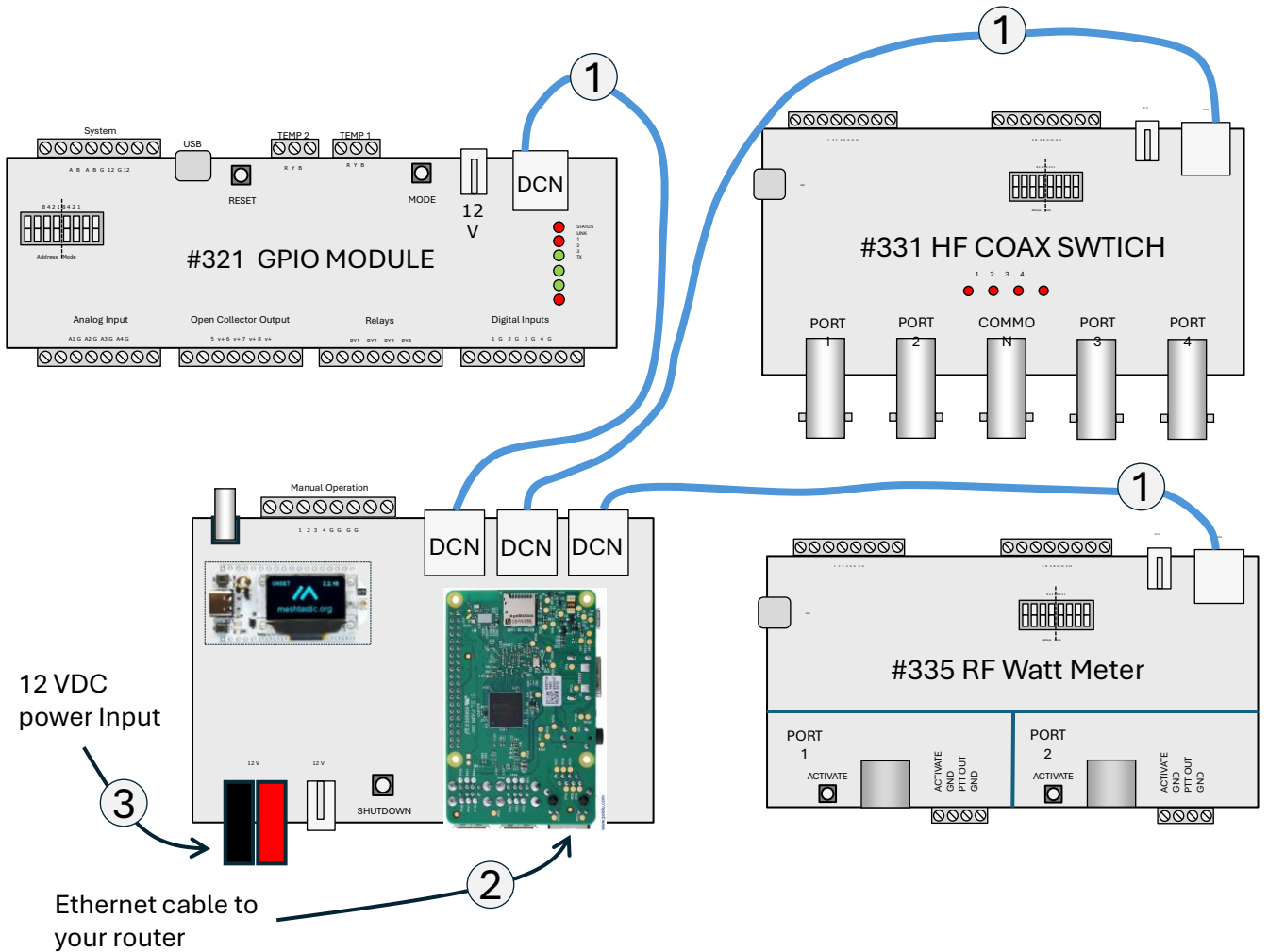

In this open example, you only need three connections to get your system up and running.

- ① CAT6 cables between the Raspberry Pi host adapter module and each of the control modules. These provide power and data to the control modules.
- ② Ethernet cable from your router to the network jack on the Raspberry Pi
- ③ 12 VDC power input to the powerpole or 2.1mm barrel jack.

Quickstart – Detailed Version (for those people who like to read more...)

If you have purchased the Sierra Radio Systems Station Controller Complete Starter Kit, you will have a Raspberry Pi with an SD card that is already configured and one or more control modules. You can also download the latest Raspberry Pi ISO SD card image from the Sierra Radio Systems web site or groups.io page.

Getting your station controller up and running is quick and easy. Follow these steps and you will up and running in just a few minutes.

Step 1 – Set up the Raspberry Pi computer module.

1. Make sure the Raspberry Pi has a SRS Station Controller SD card inserted in the micro SD card slot.
1. Connect an ethernet cable from your local area network to the RJ connector on the Raspberry Pi. Do NOT plug a live ethernet network cable into the three black RJ45 connectors along the top of the Raspberry Pi module.
1. OPTIONAL: You can connect a keyboard, mouse and monitor to your Raspberry Pi but in normal setup and use, there is no need to have any of these devices connected to your Raspberry Pi.

Step 2 – Connect the control modules.

2.1 Using the supplied mini CAT6 cables, connect your Raspberry Pi host adapter module to the one or more control modules you have purchased.

- The three black RJ45 connectors along the top of the Raspberry Pi board are NOT ethernet, they are the control ports that go to one or more control modules.
- The other side of the cable snaps into the RJ45 connector on the control modules.
- You can plug any of the control modules into the three RJ45 connectors.
- You can use your own ethernet cables. These can be up to several hundred feet in length.
- The RJ45 connector on the bottom of the module, the one on the Raspberry PI, IS YOUR ETHERNET connection to your local area network.

Step 3 – Power up your system

Apply the external 12 V DC power to either the Anderson PowerPole or 2.1mm barrel jack on the Raspberry Pi.

- The station controller runs on 12 volts DC commonly found in the station. The proper voltage range can be anywhere from 11 to 16 VDC. This means the station controller can be powered by a typical 13.8v DC power supply, a 12 volt “wall wart” power adapter, a 12v SLA battery, a 13.2v LiFePo4 battery or just about anything that can supply the proper DC voltage.
- A great combination is to use an external battery and charger system like the Bioenno LiFePo4 batteries and their charger. This way the station controller is always running on battery backup power. Simply plug the Bioenno charger into the 2.1mm jack on the battery and a powerpole cable from the battery to the station controller Raspberry Pi module.
- The control modules typically consume less than 500 ma. In most cases, much less. The Raspberry Pi will consume between 500ma and 5 amps depending on the model. On the average, they consume 500ma to 1000ma.
- We recommend the Raspberry Pi 3 because it is fast enough to run the station control dashboard application and it is very power efficient for a linux computer.
- You can also run higher power computers like the Raspberry Pi 4 or 5 or any computer that can run Node Red.
- If you run a Raspberry Pi 5 with the station controller we recommend using your own external 5v 5A power supply to power the Raspberry Pi but the station controller still needs its 12 V DC power.

Step 4 – Set up a user computer that will be interfacing to the control system

3.1 You will be using your own computer to access the station controller’s dashboard through a web browser. This can be any computer (Windows, Mac, Linux). Most tablets and phones will also work but the dashboard layout may not be ideal.

Connect this computer to your local area network by ethernet or WiFi.

3.2 Get the IP address of the station controller. There are multiple ways to do this.

- #1 – When the system controller boots up, after about 1 minute, the controller will send a message to all of the attached control modules telling them to display the station controller’s IP address.
- #2 – You can log into the Raspberry Pi with the keyboard, mouse and monitor and click on the up/down arrows in the upper right corner to display the address.
- #3 – You can log into the Raspberry Pi and execute the station controller menu utility by launching a command window and entering “menu” return. Select the “get my ip address” option.
- #4 – Using a program like Putty, you can ssh into the Raspberry Pi with the host name of stationcontroller on port 22. Login with user name “sierra” and a password of “61466146”. Once logged in, at the command prompt type “menu” and hit the enter key. In the station controller utility select “get my ip address” and the address will be displayed.

Once you have the IP address of the Raspberry Pi you point your browser of your user computer to the IP address followed by :1880/ui

For example if the Raspberry Pi’s address is 192.168.1.101 you would go to 192.168.1.101:1880/ui

This will bring up the station control system dashboard.

Step 5 – Start using the station controller

That’s it ! You are ready to test out your station control system. Of course at this point you will want to start wiring up your station controller to the real world. Check out the section on wiring the station controller to your station.